

Industeel

Creusabro[®] 4800



Creusabro[®] 4800 : advanced technology in wear

Creusabro[®] 4800 is a high performance wear resistant steel, exhibiting a wear resistance 50% higher than that of conventional 400HB water quenched steel.

Rather than relying exclusively on a high hardness level, properties of **Creusabro[®] 4800** are improved as a result of the combination of an enriched alloying content (chromium, nickel, molybdenum and titanium) and specific heat treatment procedures. **Creusabro[®] 4800** is designed to offer the best possible optimization of an exceptional wear resistance and very acceptable workability.

The moderate hardness of **Creusabro[®] 4800** in the as delivered condition makes processing operations like cutting, machining and forming easier and far better than ordinary water quenched steels.

When in service, **Creusabro[®] 4800** strongly improves its wear resistance by a surface hardening effect of about +70 HB under the action of local plastic deformations caused by impact with rocks or pressure by the abrasive particles.

Creusabro[®] 4800 is ideal for applications in mines and quarries, cement and steelmaking industries, public works and agricultural machinery. The grade is suitable for all types of abrasion, sliding or impact, dry or wet environments, including operating temperatures up to 450°C.

Properties

Standards

Creusabro[®] 4800 is a proprietary and exclusive grade developed by Industeel. There exists no engineering standard for plates intended for wear resistant applications.

Chemical Analysis - % Weight (Max. values).

C	S	P	Mn	Ni	Cr	Mo
≤ 0.20	≤ 0.005	≤ .018	≤ 1.6	≤ 1.0	≤ 1.9	≤ 0.40

Mechanical Properties (Indicative values).

Hardness (HB)	Y S MPa (ksi)	UTS MPa (ksi)	Elongation 5.65 %	KCVL - 40°C/°F J (ft.lb)	Elasticity modulus GPa
370	900 (130)	1200 (174)	12	50 ⁽¹⁾ (37)	205

Guaranteed values (as supplied) Hardness 350 - 420 HB

(1) typical value Thickness 30 to 120 mm

Physical Properties

Average Expansion coefficient (x 10 - 6.°C - 1)

20/100°C (68/212°F)	20/200°C (68/392°F)	20/300°C (68/572°F)	20/400°C (68/752°F)	20/500°C (68/932°F)	20/600°C (68/1112°F)
12.4	13.1	13.9	14.4	14.7	15.0

Metallurgical Concept

Abrasion resistance is not exclusively associated with the hardness of the steel in the supplied condition. Also the chemical composition and metallurgical structure strongly influence the actual performance in service. The balanced chemical composition and the manufacturing processes applied to **Creusabro® 4800** develop a metallurgical structure, which contributes strongly to the improvement of its wear resistance through effects described here after:

Work hardening in service

When entering in service, **Creusabro® 4800** exhibits a surface hardening of about 70 HB whatever the applied strain level is (impact, pressure...)

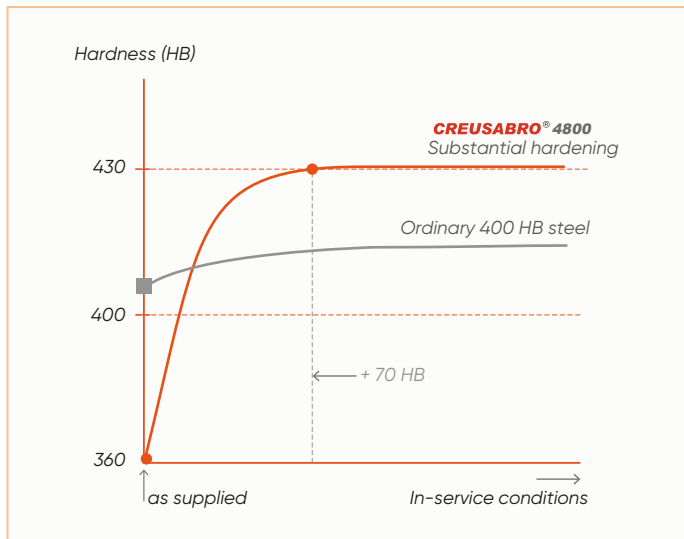

Delay of chip removal

Creusabro® 4800 has the advantage of a higher capacity for plastic deformation caused by impacts. This improved ductility contributes to a delay in the chip removal from the steel by abrasive particles, thus ensuring a slower wear rate (weight loss) than on ordinary water quenched steels.

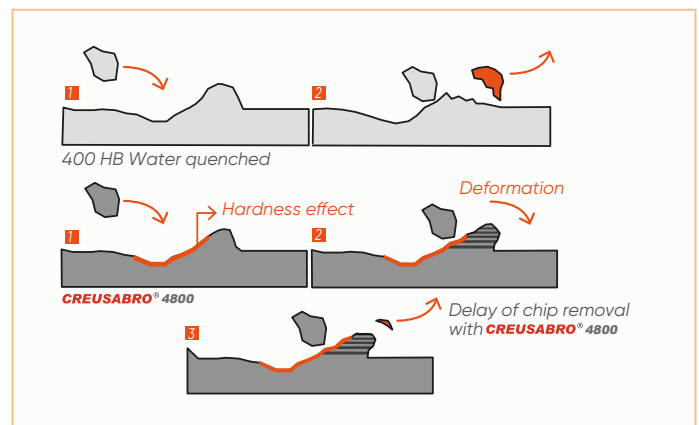

Fine dispersion of micro carbides

Fine and homogeneous distribution of chromium, molybdenum and titanium (for Creusabro® Dual) carbides. These carbides, respectively 1500 HV, 1800 HV and 3200 HV, provide to the steel an increased wear resistance.

	400 HB water quenched Conventional route Passive material	Creusabro® 4800 Innovative route Active material
Wear resistance	Just connected to supplied hardness	Combining: - in service hardening - TRIP effect - Microcarbides
	PASSIVE STEEL	REACTIVE STEEL
Process	- Low alloyed steel (C, Mn, B) - Water quenching	- Specific addition of alloying elements (Cr, Mo, B, Ti...) - Controlled cooling rate
Structure	100% martensitic structure	Structure: bainite/martensite + retained austenite + micro - carbides - Transformation of retained austenite into fresh martensite under abrasive effect - Fine dispersion of very hard micro - carbides

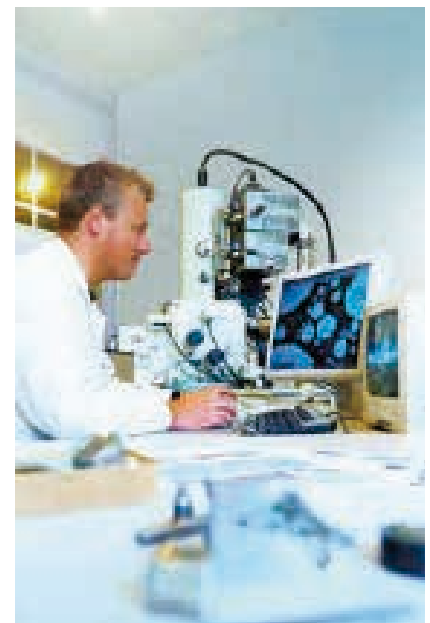

Properties At High Temperature

Creusabro® 4800 chemical composition, chromium and molybdenum contents principally give a high resistance to softening in hot conditions, much better than that of 400 HB water quenched steel.

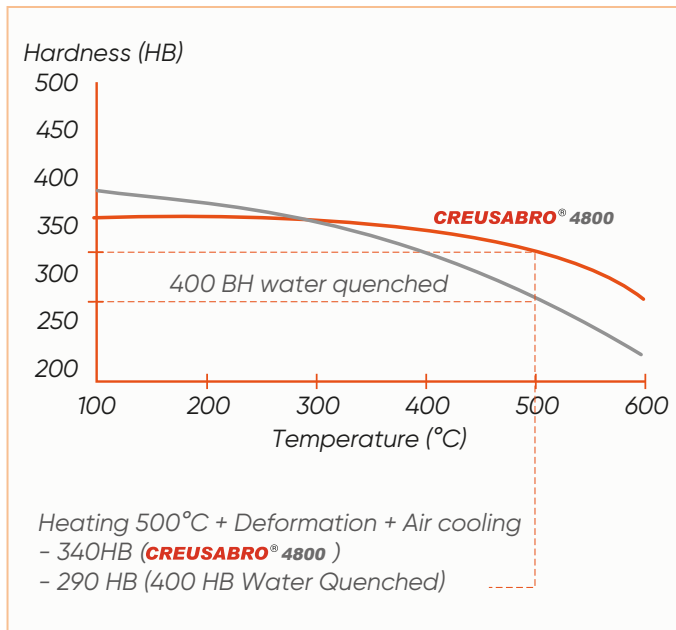

These properties enable the steel to be processed in the hot condition 450- 500°C (840 - 930°F): forming of thick plates, for example, followed by a slow cooling without inducing any significant drop of hardness. Hot resistance of **Creusabro® 4800** allows its use in hot environments where pieces are heated up to 350°C (660°F).

Service life

Creusabro® 4800 metallurgical concept improves its wear resistance compared to other anti - abrasion grades available in the market, and in all service conditions.

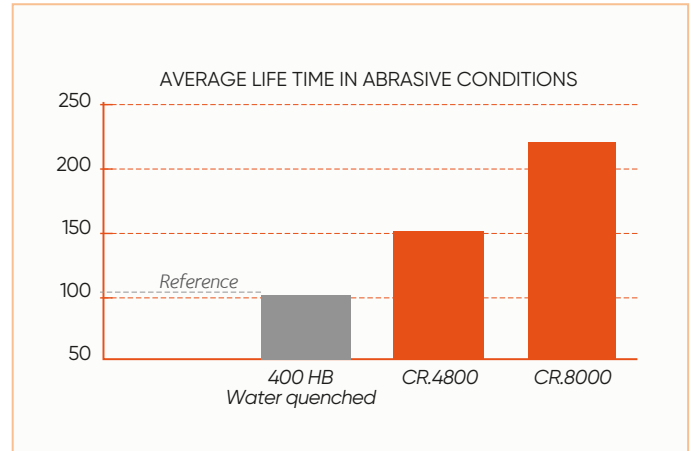

Creusabro® 4800 benefits from the optimum compromise between wear resistance and ease of processing.

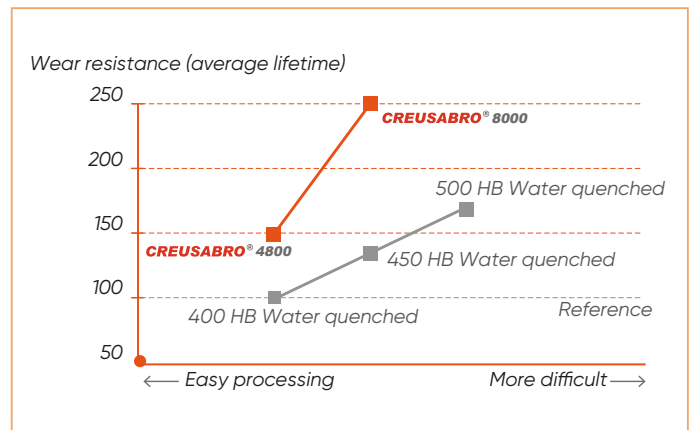

Delivery conditions

Sizes - Tolerances

Thickness	Standard sizes (mm)	Flatness
3 to 150 mm (.12" to 5.9")	1500 x 3000 (59" x 118")	5 mm/m (.2")
	2000 x 6000 (79" x 236")	
	2500 x 8000 (98" x 315")	

Other dimensions available on request.

Plate processing

Cutting

All classical thermal processes (oxygen - plasma - laser) can be used. Plasma and laser processes are especially recommended, to obtain better precision and cutting aspect and to minimize the extend of the Heat Affected Zone (HAZ). Whatever process (thermal) is used, following conditions are sufficient to avoid any cold cracking:

Plate temperature	Thickness < 60 mm (2.4")	Thickness > 60 mm (2.4")
≥ 10°C (50°F)	No preheating	Preheating 150°C (302°F)
< 10°C (50°F)	All thicknesses: preheating 150°C (302°F)	

Water jet cutting also can be used.

Machining

Drilling could be done with high speed tools, HSSCO type. (ex. AR 2.9.1.8 according to AFNOR, M42 according to AISI) Lubrication with soluble oil diluted to 20%.

Tool	Ø mm	Cutting speed (m/min)	Revolution Speed (rev/min)	Feed mm/rev
HSSCO AR.2.9.1.8 (M42)	5	15 - 20	950 - 1250	.07
	10	13 - 17	415 - 540	.09
	15	12 - 15	255 - 320	.10
	20	11 - 14	175 - 220	.12
	25	9 - 12	115 - 150	.15
	30	8 - 10	85 - 105	.20

Milling could be done with cutting tool with insert F40 m. Lubrication with soluble oil.

Tool	Depth (mm)	Cutting speed (m/min)	Feed tooth
F40M Ø 12mm	1-5	70-200	.12-.35

Indicative parameters

Forming

Cold forming of **Creusabro 4800** can be done without any problem when the following conditions are met:

- > No marks or scratches in shaped zones, mainly on external face
- > Bevelling by grinding of edge angle especially on extended skin. If required grinding to remove cutting heterogeneities
- > Minimum internal bending radius (table below),
- > Plate temperature > 10°C (50°F).

Bending

Min internal bending radius

th=thickness

⊥ to rolling direction	$r_i \geq 3 \text{ th}$
// to rolling	$r_i \geq 4 \text{ th}$
Die opening V (mini)	$V \geq 12 \text{ th}$

The bending force depends on UTS plate thickness, bended length and die opening V.

Indicative values, for die opening $V = 12\text{th}$ (V bending)

Th plates (mm)	Bending strength L = 1 m (ton/m)
5	70
10	130
20	250

Spring back: allows for a tight bending angle to compensate spring back effect.

Example: for $r_i / \text{th} = 5$, anticipate an angular correction of about 10°.

Safety: Due to high elastic energy of the steel it is advised not to stand in front of the machine, but at the side.

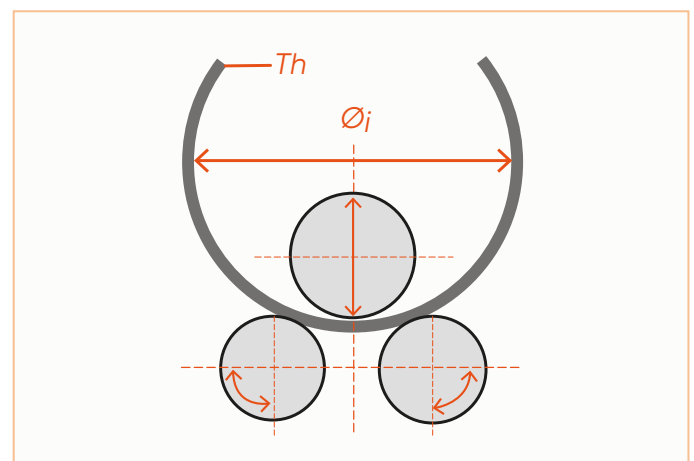
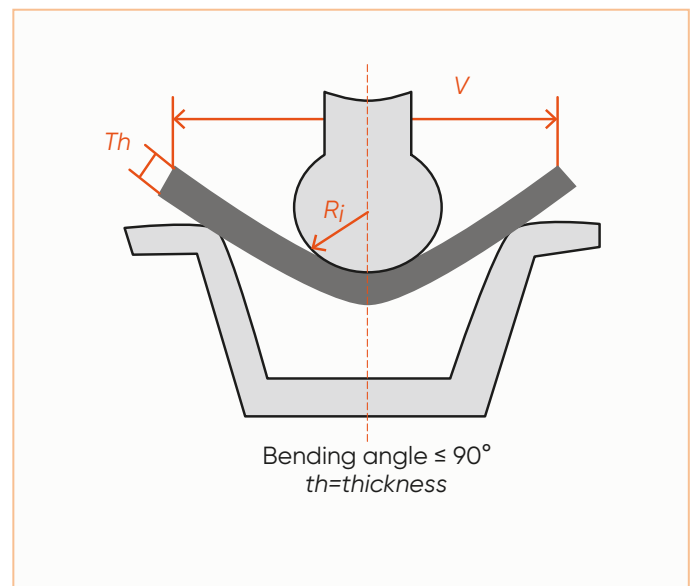

Rolling has to be done using the following conditions:

$\varnothing i \geq 30$ th plate temperature $> 10^{\circ}\text{C}$ (50°F). The force required to roll a plate will be about double that of a S355 type steel.

Creusabro® 4800 can be hot formed at a temperature of $450 - 500^{\circ}\text{C}$ ($840 - 930^{\circ}\text{F}$) without any further heat treatment. At this temperature the force necessary to deform the plate will be lower than at room temperature, and the deformation capability of the steel will be higher (smaller forming radius).

It is possible to hot form a Creusabro® 4800 plate of thickness ≤ 20 mm ($.78''$) within temperature range $870 - 1000^{\circ}\text{C}$ ($1600 - 1830^{\circ}\text{F}$) followed by air cooling without affecting steel properties. This process is particularly interesting to reduce bending / rolling forces and to increase the deformation capability of the steel.

Welding

Creusabro® 4800 (ISO/TR 15608 class 3.3) can be welded by all traditional welding processes: manual, semi - automatic under gas, automatic under fluxes. For welds non exposed to wear, the following welding products can be used.

Processes	AFNOR	DIN	AWS
Manual Stick electrode	A81-309 E51 4/3 B	DIN 1913 Class E51 43 B10	AWS 5-1 Class E7016 or 7018
Semi - automatic Under gas	A81311 GS2	DIN 8559 SG2	AWS A-5-18 Class ER70S4 or ER 70S6
	A81350 TGS 51BH TGS 47BH	DIN 8559 SGB1 CY 4255	AWS-5-20 Class ER 71T5

For welds exposed to wear, please ask for advice on the choice of welding products and processes and parameters. Welded area must be free of grease, water, oxides... As best practice, we recommend a minimum preheat of 120°C (250°F) to ensure the joint is dry. Electrodes and flux shall be stoved according to supplier recommendations. Following preheating conditions can be used when welding in a dry controlled environment and provided the weld joint is not subject to excessive stress.

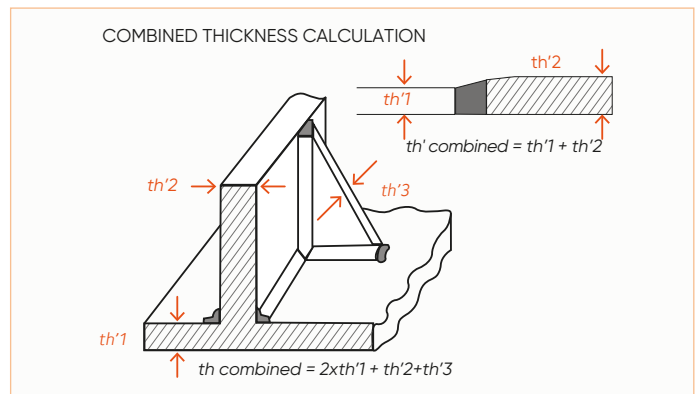

Combined thickness mm (inch)		30	40	50	60	70	80	90
Heat input (kJ/cm)	15							
	30	(1.18)	(1.57)	(1.96)	(2.36)	(2.75)	(3.14)	(3.54)

Semi - automatic under gas	15							
	30							
Manual welding Stick electrode	10							
	20							
Automatic under solid flux	20							
	30							

- Without pre - heating
- Pre - postheating at 75°C (167°F)
- Pre - postheating at 125°C (257°F)



Applications

> Quarries - Public works: Blades, Bucket liners, crusher lateral stiffeners, screens, dumper bodies and trommels...

Quarries - Public works: Blades, Bucket liners, crusher lateral stiffeners, screens, dumper bodies and trommels...

> Mines: Extraction equipment, conveyor bottom plates, hoppers, helical gravity and screw conveyors, skips, ventilators, discharge plates...

> Cement plants: Wheel excavators buckets, crusher lateral shield, clinker chutes, buckets, ventilators, dust separators, bagging machines...

> Steel plants: Guiding plates, hoppers, chutes, discharge plates, scrap containers/charging boxes...



Your contacts

Gilles Hauden

Gilles.Hauden@arcelormittal.com

Industeel France

Le Creusot Plant

56 rue Clemenceau

F - 71202 Le Creusot Cedex

<https://industeel.arcelormittal.com>

Technical data and information are to the best of our knowledge at the time of printing. However, they may be subject to some slight variations due to our ongoing research programme on steels. Therefore, we suggest that information be verified at time of enquiry or order. Furthermore, in service, real conditions are specific for each application. The data presented here are only for the purpose of description, and considered as guarantees when written formal approval has been delivered by our company. Further information may be obtained from the address opposite.

Creusabro® 4800 . 11/2022