

Amstrong® Ultra 890QL

Amstrong® Ultra 890QL: a High Yield Strength steel for welded and weight - saving structures

Amstrong® Ultra 890QL is a quenched and tempered steel for structure with higher strength.

Thanks to a minimum yield strength of 890 N/mm² (130 ksi), Amstrong® Ultra 890QL enables to make weight savings or support higher stresses and thus carry higher payload.

With a good quality of steel making process, an adapted chemical analysis (low alloying content) and an excellent precision in our fabrication process (thickness tolerance, uniform mechanical characteristics), Amstrong® Ultra 890QL is easy to machine, to bend and to weld which simplify production and maintenance.

By using Amstrong® Ultra 890QL and thus thinner plate in welded structures, you limit preheating conditions, you decrease quantity of consumables, welding time and so production costs.

PROPERTIES

STANDARDS

Amstrong® Ultra 890QL fulfills the requirements of S890QL according to EN 10025-6 standard, last edition.

CHEMICAL ANALYSIS - WEIGHT% max

C	Mn	Si	Cr	Mo	P	S	V	Ni	Cu	Al
0.18	1.50	0.50	0.70	.70	.020	.010	.10	1.6	.30	.018 to .060

CARBON EQUIVALENT

$C_{eq} = C + \frac{Mn}{6} + \frac{Cr+Mo+V}{5} + \frac{Ni+Cu}{15}$ $CET = C + \frac{Mn+Mo}{10} + \frac{Cr+Cu}{20} + \frac{Ni}{40}$	Thickness range - mm (")	C.Eq	CET
	6 - 50 (.24" - 2")	≤ .59	≤ .41
	50.1 - 125 (2" - 4.92")	≤ .70	≤ .44

Maximum Values

MECHANICAL PROPERTIES

Thickness range mm (")	Yield Strength R _{eH} (MPa)	Tensile Strength R _m (MPa)	Min Elongation Al ₀ = 5.65√So (%)
6 - 50 (.24" - 2")	890 (130)	940 - 1100 (137 - 160)	11
50.1 - 125 (2" - 4.92")	830 (120)	880 - 1100 (128 - 159)	11

Minimum values

PROPERTIES

PHYSICAL PROPERTIES

Impact tests

Minimum value (guaranteed on 3 tests), according to EN 10 125 - 6

Temperature	Longitudinal direction	Transversal direction
- 40°C (- 40°F)	40 J (29 ft.lbs)	30 J (22 ft.lbs)

For 6 mm (.24") ≤ th ≤ 10 (.39"), subsize specimen will be used and requirement adapted accordingly.

DELIVERY CONDITIONS

SIZES AND TOLERANCES

Thicknesses		Quarto			Flatness* mm per 2 m
mm	inches	Width mm	Width feet	Tol./Th mm	
5 - 7	.20 - .24	1200 - 2000	4.92 - 6.56	± 0.5	14
8 - 10	.35 - .39	1200 - 3000	4.92 - 9.84	± 0.5	8
11 - 14	.43 - .35	1200 - 3000	4.92 - 11.48	± 0.5	8
15 - 24	.59 - .94	1200 - 3000	4.92 - 11.48	± 0.7	8
25 - 39	.98 - 1.53	1200 - 3000	4.92 - 11.48	± 0.8	8
40 - 59	1.57 - 2.32	1200 - 3000	4.92 - 11.48	± 1.2	8
60 - 125	2.36 - 4.92	1200 - 3000	4.92 - 11.48	± 1.4	8

Maximum length = 13 m. (42.65')

* Tighter flatness can be achieved upon request.

PLATE PROCESSING

FORMING

Thanks to the quality of steel making process, Armstrong® Ultra 890QL is easy to shape providing the following conditions are respected:

- Dressing (or grinding) of the ridges caused by gascutting to limit the hardened zones
- Sufficiently powerful equipment
- Respect of minimum forming radius

	Perpendicular to the rolling direction	Parallel to the rolling direction
Bending internal radius R_i (mini)	2.5 x th	3.5 x th
Die opening V (mini)	8.5 x th	10 x th

th = thickness

In hot condition, Armstrong® Ultra 890QL is unsuitable for hot forming at a temperature higher than 600°C (1110°F).

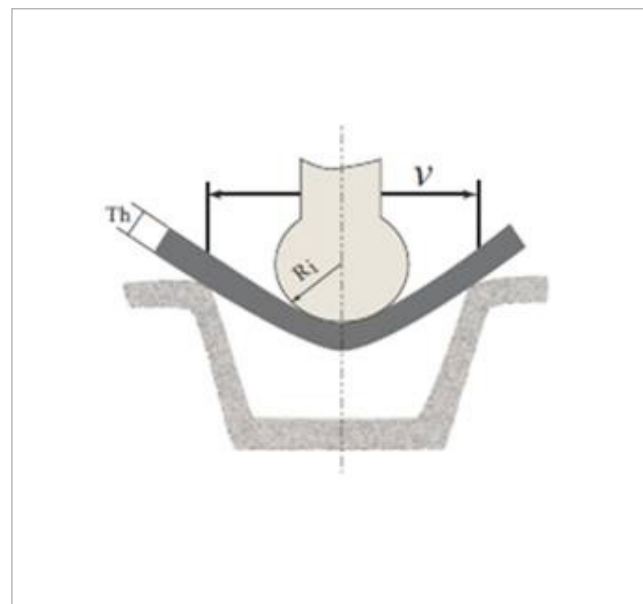

MACHINING

Amstrong® Ultra 890QL can be machined without any difficulty using the same methods as those used for the classical steels.



WELDING

The reduced carbon and alloying elements content of Armstrong® Ultra 890QL allow welding in very good conditions with excellent characteristics.

Weld preparation

The preparation of joints and surfaces is obviously very important to work in safe conditions:

- > Removing all traces of grease and water
- > Grinding of cuts to remove any oxides, slag of grooves from cutting with excessive oxygen pressure
- > Grinding of any sheared edges, tears, final drips

Welding process

Any arc welding process may weld Armstrong® Ultra 890QL. Manual welding with basic coated electrodes, semi automatic or automatic, with shielded or submerged arc welding, or laser can be chosen according to the criteria of workshop know - how and economics.

Welding energy

The Heat input to avoid toughness loss shall not exceed 15kJ/mm.

Preheating

Amstrong® Ultra 890QL can be welded without any crack risk according to recommended conditions (forecast for highly clamped weld) in following these preheating conditions:

Thickness	Hydrogen content	Pre - heating température	Post - heating
< 15 mm (5/8")	H ₂ < 5 ml/100 g (FCAW, GMAW)	No pre - heating	Not required
	H ₂ > 5 ml/100 g (SMAW, SAW)	No pre - heating	Not required
15 to 50 mm (5/8" to 2")	H ₂ < 5 ml/100 g (FCAW, GMAW)	130°C (265°F)	Not required
	H ₂ > 5 ml/100 g (SMAW, SAW)	130°C (265°F)	100°C/2H (210°F/2h)
50 to 125 mm (2" to 4.92")	H ₂ < 5 ml/100 g (FCAW, GMAW)	150°C (300°F)	Not required
	H ₂ > 5 ml/100 g (SMAW, SAW)	150°C (300°F)	150°C/2H (300°F/2h)

For control of the preheating, the temperature must be checked on the opposite side of the plate and at 100 mm (3.93") from the axis of the weld. A contact thermometer or thermo sticks are recommended for this control. Interpass Temperature must be lower than 200°C (390°F) max.

Filler materials

Electrodes and fluxes should be re-dried at 350°C (660°F) for minimum 2 hours (specified on label) and stored at 120-150°C (250-300°F) in holding oven or heated quiver before welding to maintain the lowest possible hydrogen content.

PLATE PROCESSING

Process	SMAW	GMAW	FCAW	SAW
Standard	AWS 5.5 EN ISO 18275	AWS 5.28 EN ISO 16834	AWS 5.36 EN ISO 18276	AWS 5.23 EN ISO 26304
VABW	BÖHLER FOX EV 100 E12018-G E 89 4 Mn2Ni1CrMo B 4 2 H5	Union X96 ER120S-G G 89 5 M21 Mn4Ni2,5CrMo	BÖHLER Kb 90 T-FD E120T5-M21A4-GH4 T89 4 Mn2Ni1CrMo B M 3 H5	
ESAB	OK 75.78 E 89 6 Mn 3 NiCrMo B 42 H5	OK AristoRod 89 ER120S-G G89 4 M Mn4Ni2CrMo	Coreweld 89 E120T15-M21A4-G-H4 T 89 4 Z M M 3 H5	
FSH		SELECTARC F79G ER120S-G G 89 4 M21 Mn4Ni2CrMo	SELECTARC FCW 79-M E120C-H4 T 89 6 Z M M 1 H5	
OERLIKON	TENACITO 100 E 12018-G H4 E 89 4 Mn2Ni1CrMo B 4 2 H5	CARBOFIL 2NiMoCr ER 120 S-G G 89 4 M21 Mn4Ni2CrMo	FLUXOFIL 45 E120T5-GM-H4 T 89 4 Z B M 2 H5	FLUXOCORD 45 / OP121TTW

These lists of filler materials have been determined according to suppliers datas, please confirm this choice for your application with your supplier.

APPLICATIONS



Excavator mounted with hydraulic breaker



Mobile crane

YOUR CONTACTS

Gilles Hauden
Tel. +33 3 85 80 53 30
gilles.hauden@arcelormittal.com

<http://industeel.arcelormittal.com>

Industeel France
Le Creusot Plant
56 rue Clémenceau
F - 71 202 Le Creusot Cedex

Technical data and information are to the best of our knowledge at the time of printing. However, they may be subject to some slight variations due to our ongoing research programme on steels. Therefore, we suggest that information be verified at time of enquiry or order. Furthermore, in service, real conditions are specific for each application. The data presented here are only for the purpose of description, and considered as guarantees when written formal approval has been delivered by our company. Further information may be obtained from the address opposite.